

A形

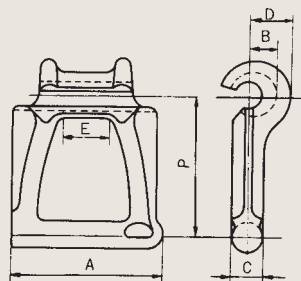

B形

チェン 番号	ピッチP		寸法(mm)					形式	一連の 個数	平均引張強さ		最大許容張力		質量(kg)	
	(mm)	(in)	A	B	C	D	E			(kN)	(kgf)	(kN)	(kgf)	1連	1m
25	22.91	0.902	19.1	5.2	3.6	—	10	A	133	3.09	315	0.49	50	1.11	0.37
32	29.31	1.154	25.4	6.4	4.3	—	13	A	104	4.90	500	0.78	80	1.72	0.57
42	34.93	1.375	32.1	7.1	5.5	—	16	A	88	7.06	720	1.07	110	2.78	0.93
45	41.40	1.630	33.3	7.6	5.5	—	18	A	74	7.55	770	1.27	130	2.48	0.83
51	29.34	1.155	31.8	9.1	6.6	—	15	A	104	8.43	860	1.47	150	3.78	1.26
52	38.25	1.506	38.8	8.7	6.7	—	16	A	80	10.2	1040	1.66	170	4.04	1.34
55	41.43	1.631	34.9	9.1	6.7	—	18	A	74	9.81	1000	1.66	170	3.38	1.13
57	58.62	2.308	44.5	10.3	6.7	—	18	A	52	12.7	1300	2.15	220	3.90	1.30
62	42.01	1.654	42.1	10.3	8.0	—	22	A	73	14.2	1450	2.35	240	5.05	1.68
67	58.62	2.308	50.8	10.9	8.0	—	18	A	52	14.7	1500	1.96	200	4.96	1.65
77	58.34	2.297	56.0	9.0	10.0	15.0	18	B	52	15.7	1600	2.64	270	7.14	2.38
78	66.27	2.609	66.7	11.1	10.7	16.7	24	B	46	24.5	2500	4.11	420	8.70	2.90
88	66.27	2.609	69.9	11.1	12.3	21.0	24	B	46	28.4	2900	4.80	490	11.50	3.83
103	78.11	3.075	83.4	15.5	14.6	25.4	28	B	39	44.1	4500	7.45	760	18.87	6.29
114	82.55	3.250	88.0	20.6	16.8	29.8	27	B	37	53.0	5400	8.92	910	25.52	8.51

A-1アタッチメント

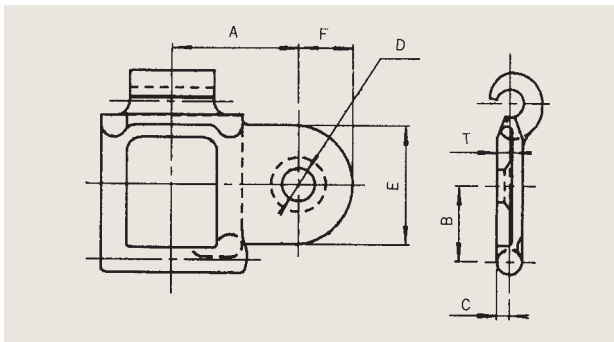

チェン 番号	寸法(mm)							質量(kg)	
	A	B	C	D	E	F	T	1連	1m
25	22.2	11.1	2.4	5.6	18.3	8.7	2.4	1.84	0.61
32	22.2	15.9	2.4	5.6	18.3	8.7	3.2	2.36	0.79
42	27.8	16.7	2.8	7.2	26.2	11.9	3.6	3.63	1.21
52	30.2	19.8	3.2	6.8	27.0	11.1	3.2	5.08	1.69

注) 左右勝手違いのものがあります。

K-1アタッチメント

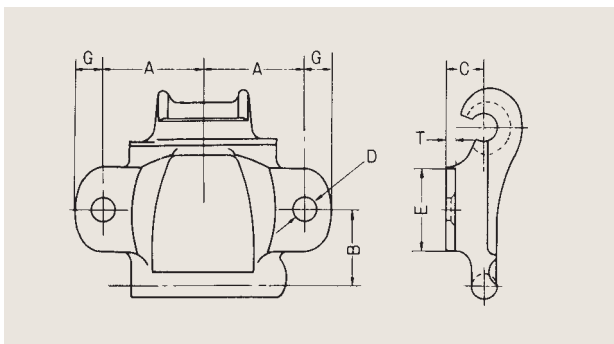

チェン 番号	寸法(mm)							質量(kg)	
	A	B	C	D*	E	G	T	1連	1m
25	15.9	12.7	8.7	4.0	11.1	5.6	2.4	2.15	0.72
32	22.2	15.1	9.5	5.6	15.1	7.1	2.4	3.42	1.14
42	25.4	17.5	9.5	5.6	19.1	8.7	3.2	4.50	1.50
45	25.4	19.8	10.3	5.6	21.4	8.7	3.2	4.31	1.44
52	30.2	18.3	11.1	5.6	22.2	11.1	3.2	6.40	2.13
55	25.4	19.8	10.3	7.0	22.2	8.7	3.2	4.80	1.60
62	30.2	21.4	11.9	7.1	23.8	11.9	4.0	7.65	2.55
77	38.1	28.6	16.7	7.1	32.5	11.1	4.0	11.40	3.80
88	48.4	31.8	19.1	8.7	34.9	11.1	4.8	16.40	5.47
103	53.2	38.1	22.2	10.3	43.7	12.7	6.4	25.35	8.45

※25～62は丸穴です。
77～103は角穴です。

K-2アタッチメント

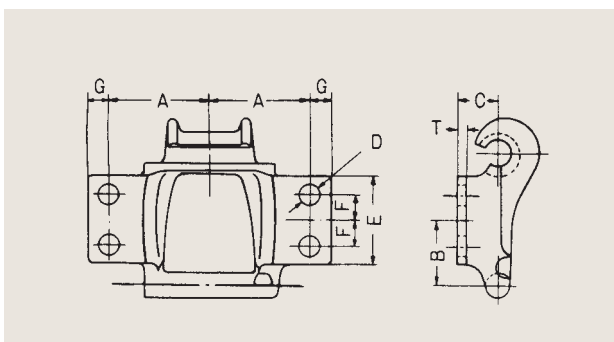

チェン 番号	寸法(mm)							質量(kg)		
	A	B	C	D	E	F	G	T	1連	1m
88	50.8	32.5	20.6	10.3	44.5	12.7	11.1	4.8	17.48	5.83