

標準形コンベヤチェン (Sローラ形)

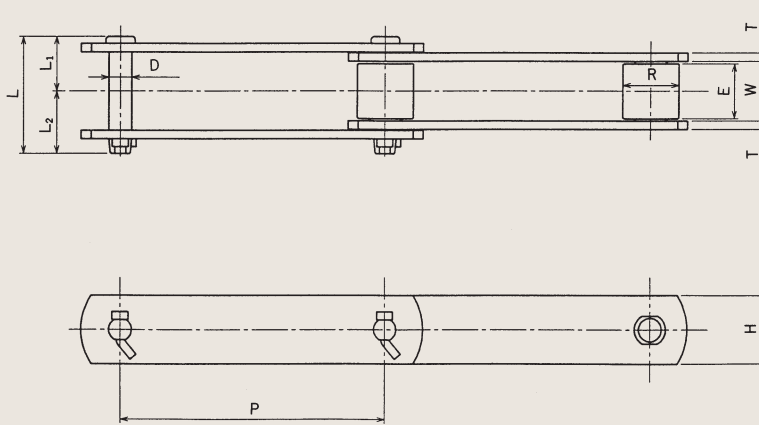

チェン 番号	チェン ピッチ P (mm)	ローラ 外径 R (mm)	内リンク 内幅 W (mm)	ピン				リンクプレート		平均引張強さ		質量 (kg/m)
				径 D (mm)	長さ			高さ H (mm)	厚さ T (mm)	(kN)	(kgf)	
					L (mm)	L ₁ (mm)	L ₂ (mm)					
HRS03075-S	75	15.9	16.0	7.9	38.0	16.8	21.2	22.2	3.2	29.4	3000	1.6
HRS03100-S	100											
HRS03150-S	150											
HRS05075-S	75	22.2	22.0	11.0	53.4	23.9	29.5	31.8	4.7	68.6	7000	4.1
HRS05100-S	100											
HRS05150-S	150											
HR10105-S	101.6	20.1	22.6	9.5	53.0	24.2	28.8	25.4	4.7	53.9	5500	3.0
HR6608-S	66.27											
HR10108-S	101.6											
HR15208-S	152.4	25.4	30.2	11.0	68.0	31.4	36.6	38.1	6.3	78.5	8000	6.0
HR10011-S	100											
HR15011-S	150											
HR7813-S	78.11	31.8	37.1	15.8	87.5	40.0	47.5	38.1	7.9	132.4	13500	10.4
HR10113-S	101.6											
HR15215-S	152.4											
HR20015-S	200	34.9	37.1	15.8	87.5	40.0	47.5	44.5	7.9	186.3	19000	8.4
HR25015-S	250											
HR15219-S	152.4											
HR20019-S	200	39.7	37.1	18.9	97.1	44.3	52.8	50.8	9.5	245.2	25000	12.6
HR25019-S	250											
HR30019-S	300											
HR20026-S	200	44.5	57.2	22.1	119.6	55.3	64.3	63.5	9.5	313.8	32000	16.5
HR25026-S	250											
HR30026-S	300											
HR45026-S	450											
HR30048-S	300	50.8	66.7	25.2	143.7	67.6	76.1	76.2	12.7	475.6	48500	22.9
HR45048-S	450											
HR60048-S	600											
HR30054-S	300	57.2	77.0	31.6	169.3	81.6	87.7	76.2	16.0	529.6	54000	29.7
HR45054-S	450											
HR60054-S	600											