

Chains for Water Treatment Systems

Roller Shoes

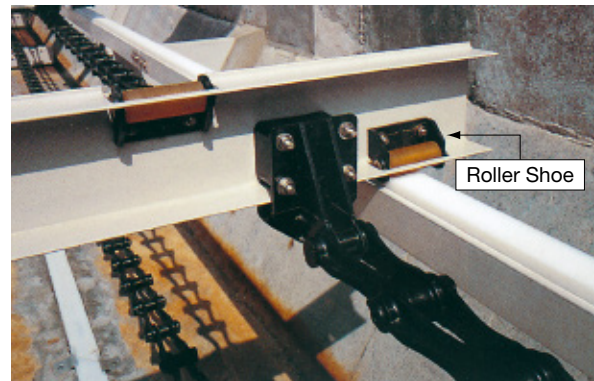

Roller shoes have the following characteristics, compared to traditional sliding shoes:

- Contact with the rail rolls rather than slides, extending lifespan.
- Reduced rolling resistance cuts running costs.
- Rail wear is reduced by rolling contact.
- The rollers can be replaced separately.

Type	Dimension L (mm)	Mass (kg)
Under type	50	1.1
	60	1.2
	70	1.3
Side type	—	1.0
FRP type	—	0.5

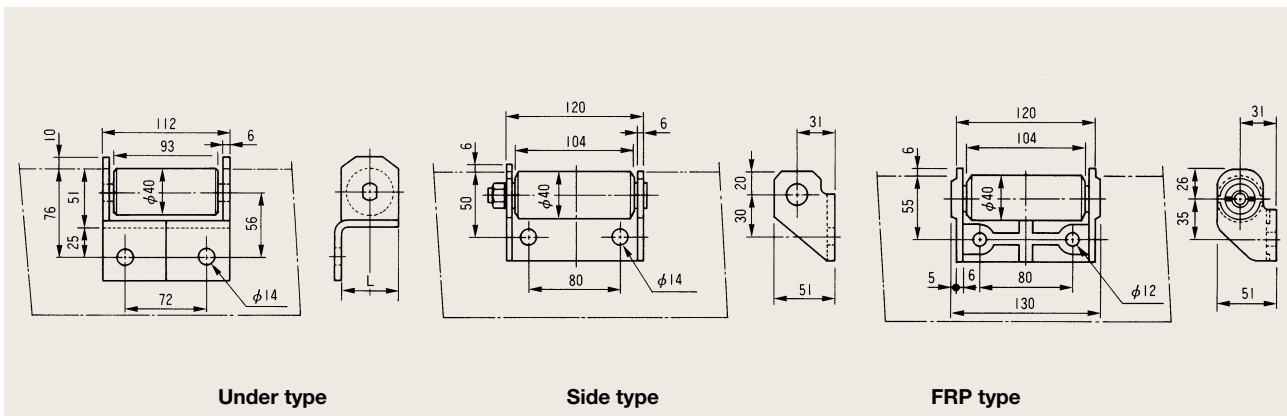

Note

- The rails should be made from stainless steel or plastic.
- Side-type shoes should be attached alternately, as shown in the diagram on the right, to ensure balance of the flights.
- Remove any foreign bodies (spatter, mortar fragments, etc.) from on the rail before running the machinery.

