

## Attachment types and Dimensions

### A-1, A-2, K-1, K-2 Attachments

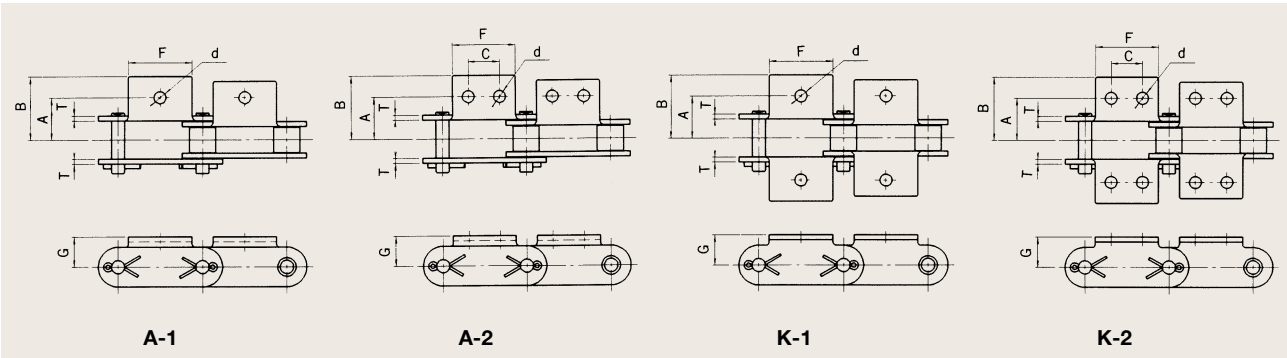

Chain No.	Dimensions (mm)							Added Mass per Attachment (g)	
	A	B	C	d	F	G	T	A-1, A-2	K-1, K-2
C2040	12.7	19.1	9.5	3.6	19.1	9.1	1.5	3.2	6.4
C2042									
C2050	15.9	24.2	11.9	5.2	23.8	11.1	2.0	6.3	12.6
C2052									
C2060H	21.4	31.2	14.3	5.2	28.6	14.7	3.2	14.9	29.8
C2062H									
C2080H	27.8	40.6	19.1	6.8	38.1	19.1	4.0	31.5	63.0
C2082H									
C2100H	33.3	50.0	23.8	8.8	47.6	23.4	4.8	64.0	128.0
C2102H									
C2120H	39.7	61.9	28.6	10.5	57.2	27.8	5.6	102.0	204.0
C2122H									
C2160H	52.4	76.1	38.1	14.0	76.2	36.5	7.2	262.0	524.0
C2162H									

### SA-1, SA-2, SK-1, SK-2 Attachments

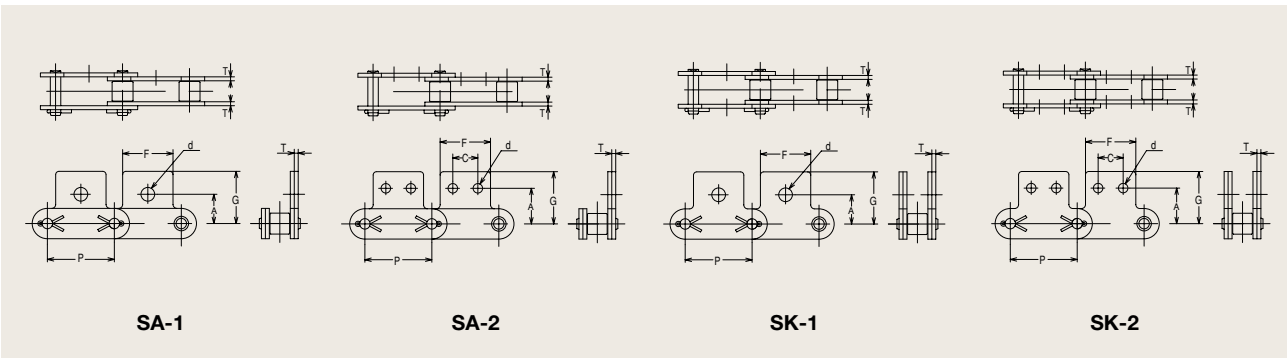

Chain No.	Dimensions (mm)						Added Mass per Attachment			
	A		C	d		F	G	T	SA-1 SA-2	SK-1 SK-2
	SA-1, SK-1	SA-2, SK-2		SA-1, SK-1	SA-2, SK-2					
C2040	11.1	13.5	9.5	5.2	3.6	19.1	19.8	1.5	2.7	5.4
C2042										
C2050	14.3	15.9	11.9	6.8	5.2	23.8	24.6	2.0	5.9	11.8
C2052										
C2060H	17.5	19.1	14.3	8.8	5.2	28.6	30.6	3.2	14.4	28.8
C2062H										
C2080H	22.2	25.4	19.1	10.5	6.8	38.1	40.2	4.0	31.5	63.0
C2082H										
C2100H	28.6	31.8	23.8	14.0	8.8	47.6	50.3	4.8	66.0	132.0
C2102H										
C2120H	33.3	37.3	28.6	16.0	10.5	57.2	61.1	5.6	97.0	194.0
C2122H										
C2160H	44.5	50.8	38.1	21.0	14.0	76.2	76.2	7.2	233.0	466.0
C2162H										

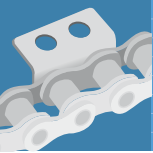

# Steel Conveyor Chains

## D-1, D-3, GK-1 Attachments

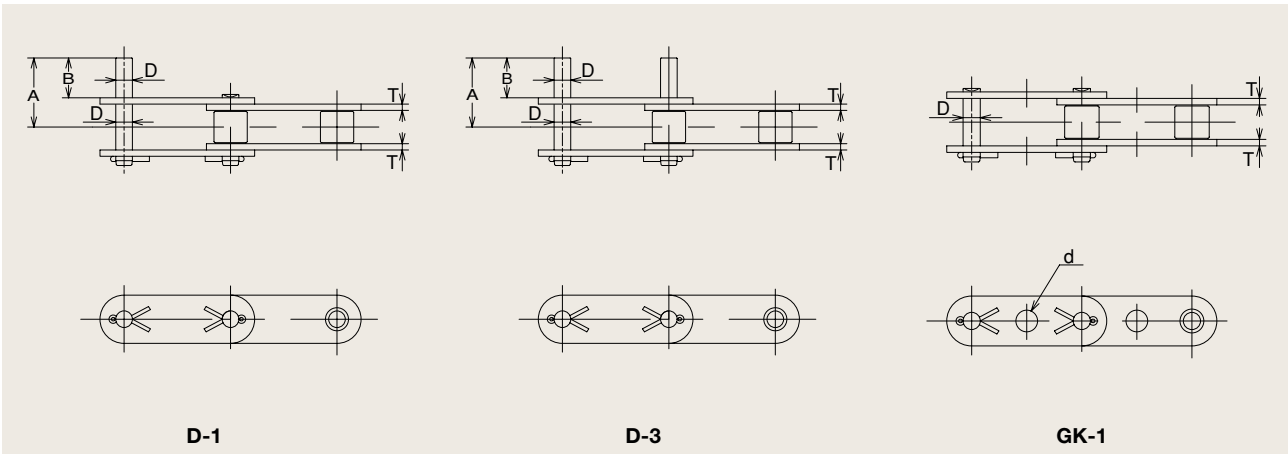

Chain No.	Dimensions (mm)					Added Mass per Attachment (g)	
	A	B	D	*d	T	D-1	D-3
			D-1, D-3	GK-1			
C2040	16.8	9.5	3.96	4.1	1.5	0.9	1.8
C2042							
C2050	21.1	11.9	5.08	6.4	2.0	1.8	3.6
C2052							
C2060H	27.5	14.3	5.95	6.4	3.2	3.0	6.0
C2062H							
C2080H	35.6	19.1	7.93	8.1	4.0	7.0	14.0
C2082H							
C2100H	43.2	23.8	9.53	10.1	4.8	12.0	24.0
C2102H							
C2120H	53.0	28.6	11.1	12.1	5.6	20.0	40.0
C2122H							
C2160H	69.0	38.1	14.28	-	7.2	44.0	88.0
C2162H							

※We also manufacture to special dimensions.