

# Chains for Water Treatment Systems

## Replaceable Piece Tooth Sprocket

Replaceable piece tooth sprocket are replacement pieces that can be bolted to the sprocket body to form a single unit. The sprocket itself is of structural steel, and the replacement tooth pieces are of stainless steel or special plastic. The replacement tooth piece can be replaced just by removing the bolts. The replacement tooth piece has a unitary structure for superior wear resistance.

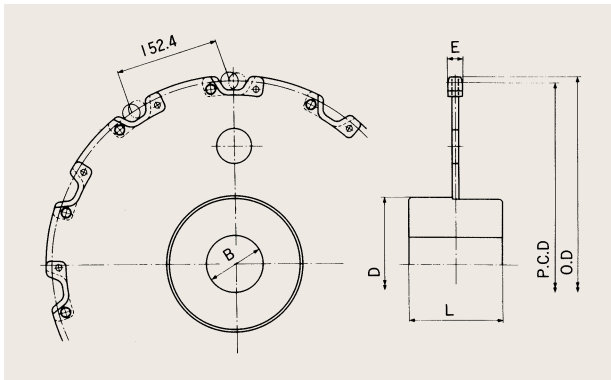
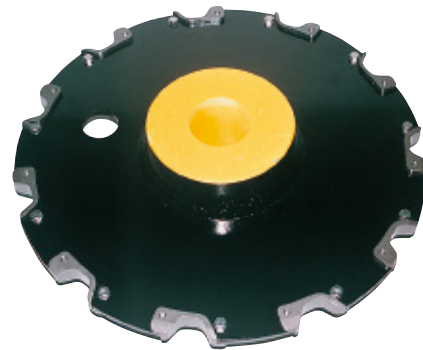

Chain No.	No. of Teeth N	Pitch Circle Dia. P.C.D. (mm)	Outer Dia. O.D. (mm)	Type	Bore Dia. B (mm)		Hub (mm)		Tooth Width E (mm)	Mass (kg)
					Pilot Bore	Maximum	Dia. D	Width L		
HSS15215-B	11	540.9	558	C type	80	125	200	140	22	45
SAV715 OSV15215-B OSV15219-B HSS15219-B	11	540.9	560	C type	80	125	200	140	25	47

Note: We can manufacture sprockets with 9-13 teeth.