

Assembled Sprockets

Assembled sprockets come in segmented and ring types.

1. Segmented type: Tooth tips are of cast stainless steel and bosses are of ductile cast iron.
2. Ring type: The tooth tips are of stainless steel or plastic and bosses are of ductile cast iron.

Assembled sprockets also help to achieve similar lifespan extension in stainless chains.

For stainless the boundary between the tooth tip and the boss is treated to prevent electrolytic corrosion.



Ring type



Segmented type

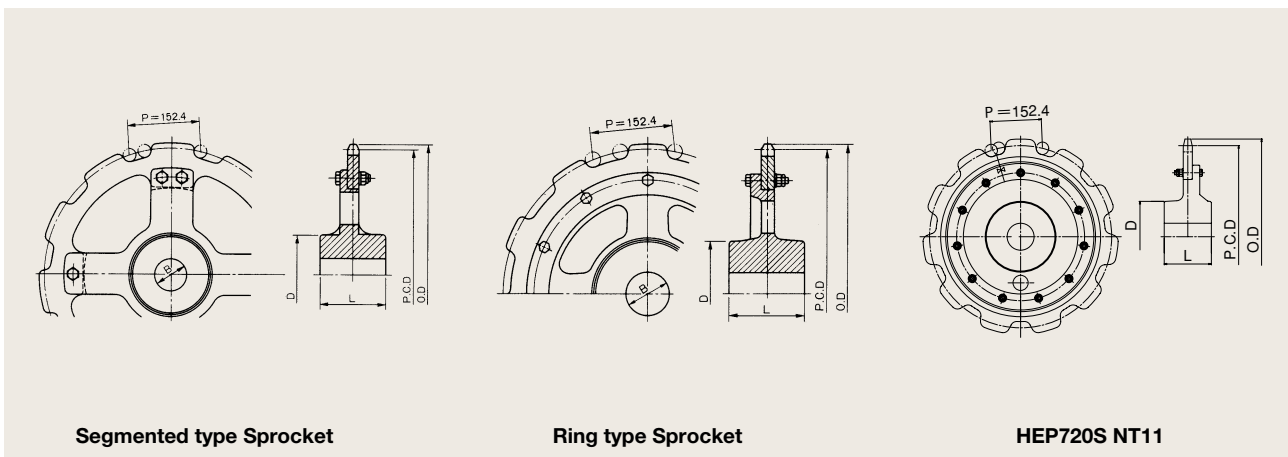

Segmented type Sprocket

Ring type Sprocket

HEP720S NT11

Plastic Sprockets and Stainless Sprockets

Chain No.	No. of Teeth N	Pitch Circle Dia. P.C.D. (mm)	Outer Dia. O.D. (mm)	Type	Bore Dia. B (mm)		Hub (mm)		Mass (kg)
					Pilot Bore	Maximum	Dia. D	Width L	
HSS15215-B	11	540.9	557	C type	80	125	200	140	(53) 55
	11	540.9	557	C type (saver type)	80	125	200	140	63
	11	540.9	558	C type	80	125	200	140	(53) 57
SAV715 OSV15215-B OSV15219-B HSS15219-B	11	540.9	560	C type	80	125	200	140	(55) 57
	11	540.9	560	Saver type	80	125	200	140	70
HEP720S	11	540.9	580	C type	80	125	210	140	(65)

Note: Figures in () are mass when tooth tips are made of plastic.