

# Steel Conveyor Chains

## Double Pitch Stainless Steel Roller Chains with Attachments

These chains are double pitch stainless steel roller chains for conveyor use, with attachments added as necessary.

### A-1, A-2, K-1, K-2 Attachments

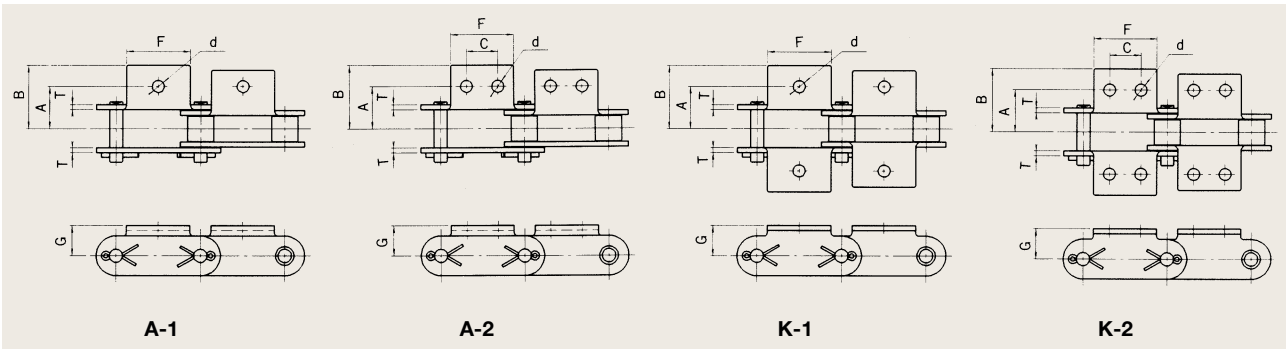

Chain No.	Dimensions (mm)							Added Mass per Attachment (g)	
	A	B	C	d	F	G	T	A-1, A-2	K-1, K-2
C2040SS	12.7	19.1	9.5	3.6	19.0	9.1	1.5	3.0	6.0
C2042SS									
C2050SS	15.9	24.2	11.9	5.2	23.8	11.1	2.0	7.0	14.0
C2052SS									
C2060HSS	21.4	31.2	14.3	5.2	28.6	14.7	3.2	17.0	34.0
C2062HSS									
C2080HSS	27.8	40.6	19.1	6.8	38.1	19.1	4.0	36.0	72.0
C2082HSS									
C2100HSS	33.3	50.0	23.8	8.8	47.6	23.4	4.8	64.0	128.0
C2102HSS									
C2120HSS	39.7	61.9	28.6	10.5	57.2	27.8	5.6	102.0	204.0
C2122HSS									

### SA-1, SA-2, SK-1, SK-2 Attachments

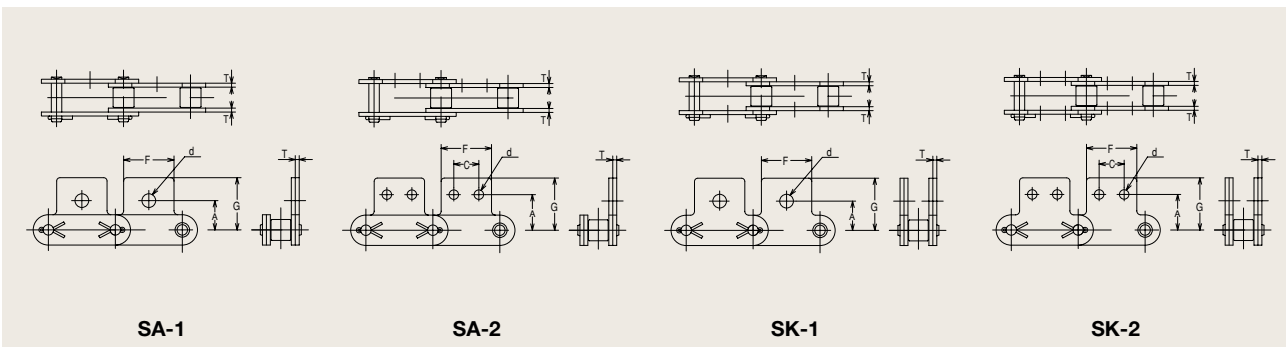

Chain No.	Dimensions (mm)						Added Mass per Attachment (g)			
	A		C	d		F	G	T	SA-1, SA-2	SK-1, SK-2
	SA-1, SK-1	SA-2, SK-2		SA-1, SK-1	SA-2, SK-2					
C2040SS	11.1	13.5	9.5	5.2	3.6	19.0	19.8	1.5	3.0	6.0
C2042SS										
C2050SS	14.3	15.9	11.9	6.8	5.2	23.8	24.6	2.0	7.0	14.0
C2052SS										
C2060HSS	17.5	19.1	14.3	8.7	5.2	28.6	31.8	3.2	17.0	34.0
C2062HSS										
C2080HSS	22.2	25.4	19.1	10.3	6.8	38.1	41.7	4.0	36.0	72.0
C2082HSS										
C2100HSS	28.6	31.8	23.8	14.0	8.8	47.6	50.3	4.8	66.0	132.0
C2102HSS										
C2120HSS	33.3	37.3	28.6	16.0	10.5	57.2	61.1	5.6	97.0	194.0
C2122HSS										