

Chains for Special Applications

HRD type Deep Link Chains

These chains are based on standard conveyor chains, but the link plate height is increased to allow conveyance of heavier objects, and an R type roller is used for reduced frictional resistance. They are mainly used in applications such as thick plate and steel section conveyance in steel works, and container assembly and movement lines.

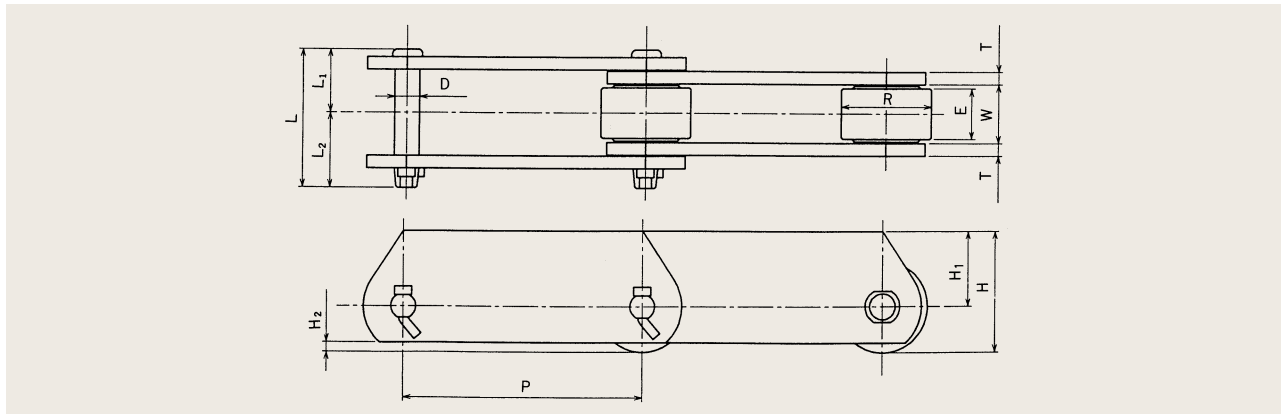

Chain No.	Pitch P (mm)	Roller		Inner Width W (mm)	Pin			Link Plate			Chain Height H (mm)
		Outer Dia R (mm)	Roller Face Width E (mm)		Dia. D (mm)	Length L1 (mm)	Length L2 (mm)	Height H1 (mm)	Height H2 (mm)	Thickness T (mm)	
HRD03100-R	100	30	14	16.1	7.9	17.1	19.3	21	4	3.2	36
HRD05100-R	100	40	19	22.2	11.1	24.0	27.0	24	4	4.5	44
HRD05150-R	150										
HRD15011-R	150	50.8	26.5	30.0	14.3	32.0	36.0	32	6.4	6.3	57.4
HRD20011-R	200										
HRD15215-R	152.4	57.2	32	37.1	15.8	40.0	47.5	35	6.1	7.9	63.6
HRD20015-R	200	65	32	37.1	15.8	40.0	47.5	41	10	7.9	73.5
HRD25015-R	250										
HRD25019-R	250	80	44	51.4	18.9	51.5	59.8	50	13.8	9.5	90
HRD30019-R	300										
HRD30026-R	300	85*	50	57.2	22.1	55.4	64.2	53	10.5	9.5	95.5
HRD30048-R	300	100*	56	66.7	25.3	67.6	76.1	62	12	12.7	112
HRD40048-R	400										
HRD45054-R	450	110*	65	77	31.6	81.6	87.7	70	17	16	125

*The outer diameters of rollers marked with an asterisk differ from standard conveyor chains and require the manufacture of specialized sprockets.

Chain No.	Allowable Load on Rollers (per 1 roller)				Average Tensile Strength				Mass (kg/m)
	Standard series		Strong series		Standard series		Strong series		
	(kN)	(kgf)	(kN)	(kgf)	(kN)	(kgf)	(kN)	(kgf)	
HRD03100-R	0.53	55	0.88	90	29.4	3000	69.6	7100	2.8
HRD05100-R	1.02	105	1.71	175	68.6	7000	142.2	14500	5.9
HRD05150-R									4.9
HRD15011-R	1.76	180	2.94	300	112.8	11500	225.6	23000	9.7
HRD20011-R									8.5
HRD15215-R	2.50	255	4.16	425	186.3	19000	279.5	28500	14.0
HRD20015-R	2.50	255	4.16	425	186.3	19000	279.5	28500	14.9
HRD25015-R									13.5
HRD25019-R	4.11	420	6.86	700	245.2	25000	387.4	39500	22.5
HRD30019-R									21.5
HRD30026-R	5.39	550	8.82	900	313.8	32000	519.8	53000	24.3
HRD30048-R	7.64	780	12.5	1280	475.6	48500	681.8	69500	39.0
HRD40048-R									34.2
HRD45054-R	10.1	1030	16.6	1700	529.6	54000	1029.7	105000	42.0