

Standard Conveyor Chains

Standard Conveyor Chains (S Roller type)

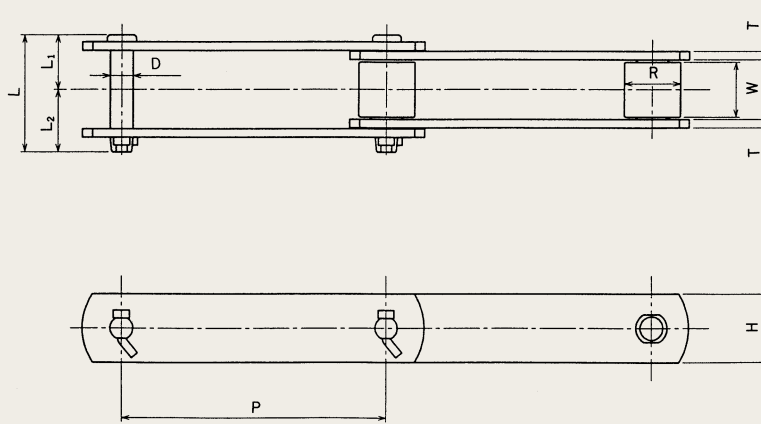

| Chain No. | Pitch P (mm) | Roller Outer Dia. R (mm) | Inner Width W (mm) | Pin | | | Link Plate | | Average Tensile Strength | | Mass (kg/m) | | | | | | | | | |
|------------|--------------|--------------------------|--------------------|-------------|--------|---------|---------------|------------------|--------------------------|-------|-------------|---------|-------|-------|------|------|-----|-------|-------|------|
| | | | | Dia. D (mm) | Length | | Height H (mm) | Thickness T (mm) | (kN) | (kgf) | | | | | | | | | | |
| | | | | | L (mm) | L1 (mm) | | | | | | L2 (mm) | | | | | | | | |
| HRS03075-S | 75 | 15.9 | 16.1 | 7.9 | 36.4 | 17.1 | 19.3 | 22.0 | 3.2 | 29.4 | 3000 | 1.8 | | | | | | | | |
| HRS03100-S | 100 | | | | | | | | | | | 1.6 | | | | | | | | |
| HRS03150-S | 150 | | | | | | | | | | | 1.2 | | | | | | | | |
| HRS05075-S | 75 | 22.2 | 22.2 | 11.1 | 51.0 | 24.0 | 27.0 | 32.0 | 4.5 | 68.6 | 7000 | 4.2 | | | | | | | | |
| HRS05100-S | 100 | | | | | | | | | | | 3.8 | | | | | | | | |
| HRS05150-S | 150 | | | | | | | | | | | 3.3 | | | | | | | | |
| HR10105-S | 101.6 | 22.2 | 27.0 | 11.1 | 51.0 | 24.0 | 27.0 | 25.4 | 4.8 | 53.9 | 5500 | 3.0 | | | | | | | | |
| HR6608-S | 66.27 | | | | | | | | | | | 5.6 | | | | | | | | |
| HR10108-S | 101.6 | | | | | | | | | | | 4.6 | | | | | | | | |
| HR15208-S | 152.4 | 25.8 | 30.0 | 14.3 | 66.0 | 31.5 | 34.5 | 38.0 | 6.3 | 78.5 | 8000 | 5.7 | | | | | | | | |
| HR10011-S | 100 | 30.0 | 30.0 | | 68.0 | 32.0 | 36.0 | 38.0 | | | | 6.3 | 112.8 | 11500 | 7.0 | | | | | |
| HR15011-S | 150 | | | | 5.8 | | | | | | | | | | | | | | | |
| HR7813-S | 78.11 | 31.8 | 37.1 | 15.8 | 87.5 | 40.0 | 47.5 | 38.1 | 7.9 | 132.4 | 13500 | 10.4 | | | | | | | | |
| HR10113-S | 101.6 | | 31.6 | | 81.3 | 37.3 | 44.0 | | | | | 8.6 | | | | | | | | |
| HR15215-S | 152.4 | 34.9 | 37.1 | 15.8 | 87.5 | 40.0 | 47.5 | 44.5 | 7.9 | 186.3 | 19000 | 9.0 | | | | | | | | |
| HR20015-S | 200 | | | | | | | | | | | 8.3 | | | | | | | | |
| HR25015-S | 250 | | | | | | | | | | | 7.8 | | | | | | | | |
| HR15219-S | 152.4 | 39.7 | 37.1 | 18.9 | 97.1 | 44.3 | 52.8 | 50.8 | 9.5 | 245.2 | 25000 | 12.7 | | | | | | | | |
| HR20019-S | 200 | | 51.4 | | | | | | | | | 18.9 | 111.3 | 51.5 | 59.8 | 50.8 | 9.5 | 245.2 | 25000 | 12.4 |
| HR25019-S | 250 | | | | | | | | | | | | | | | | | | | 11.2 |
| HR30019-S | 300 | | | | | | | | | | | | | | | | | | | 10.6 |
| HR20026-S | 200 | 44.5 | 57.2 | 22.1 | 119.6 | 55.4 | 64.2 | 63.5 | 9.5 | 313.8 | 32000 | 16.5 | | | | | | | | |
| HR25026-S | 250 | | | | | | | | | | | 14.8 | | | | | | | | |
| HR30026-S | 300 | | | | | | | | | | | 14.2 | | | | | | | | |
| HR45026-S | 450 | | | | | | | | | | | 12.5 | | | | | | | | |
| HR30048-S | 300 | 50.8 | 66.7 | 25.3 | 143.7 | 67.6 | 76.1 | 76.2 | 12.7 | 475.6 | 48500 | 23.3 | | | | | | | | |
| HR45048-S | 450 | | | | | | | | | | | 20.6 | | | | | | | | |
| HR60048-S | 600 | | | | | | | | | | | 19.2 | | | | | | | | |
| HR30054-S | 300 | 57.2 | 77.0 | 31.6 | 169.3 | 81.6 | 87.7 | 76.2 | 16.0 | 529.6 | 54000 | 29.9 | | | | | | | | |
| HR45054-S | 450 | | | | | | | | | | | 26.3 | | | | | | | | |
| HR60054-S | 600 | | | | | | | | | | | 24.4 | | | | | | | | |