

# Standard Conveyor Chains

## Standard Conveyor Chains (R Roller type)

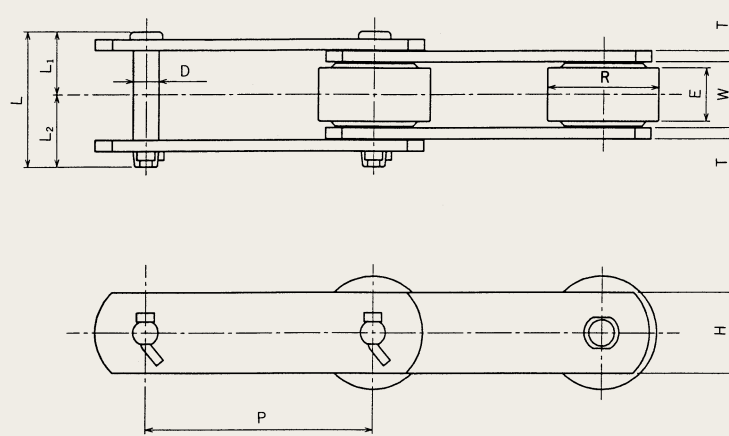

Chain No.	Pitch P (mm)	Roller		Inner Width W (mm)	Dia. D (mm)	Pin			Link Plate		Average Tensile Strength		Mass (kg/m)
		Outer Dia. R (mm)	Face Width E (mm)			Length	Height H (mm)	Thickness T (mm)	(kN)	(kgf)			
											L (mm)	L <sub>1</sub> (mm)	
HRS03075-R	75	31.8	15.5	16.1	7.9	36.4	17.1	19.3	22.0	3.2	29.4	3000	2.7
HRS03100-R	100												2.4
HRS03150-R	150												2.0
HRS05100-R	100	40.0	19.0	22.2	11.1	51.0	24.0	27.0	32.0	4.5	68.6	7000	5.0
HRS05150-R	150												4.1
HR10105-R	101.6	38.1	18.7	22.2	9.5	51.0	24.0	27.0	25.4	4.8	53.9	5500	4.3
HR10108-R	101.6	44.45	23.5	27.0	11.1	63.0	30.0	33.0	28.6	6.3	78.5	8000	6.7
HR15208-R	152.4	50.8	26.5	30.0		66.0	31.5	34.5	38.0				7.8
HR10011-R	100	50.0	26.5	30.0	14.3	68.0	32.0	36.0	38.0	6.3	112.8	11500	10.0
HR15011-R	150												7.5
HR10113-R	101.6	44.5	27.0	31.6	15.8	81.3	37.3	44.0	38.1	7.9	132.4	13500	10.2
HR15215-R	152.4	57.2	32.0	37.1	15.8	87.5	40.0	47.5	44.5	7.9	186.3	19000	11.8
HR20015-R	200	65.0											11.3
HR25015-R	250	10.3											
HR15219-R	152.4	69.9	32.5	37.1	18.9	97.1	44.3	52.8	50.8	9.5	245.2	25000	17.2
HR20019-R	200	80.0	44.0	51.4		111.3	51.5	59.8					19.3
HR25019-R	250					16.8							
HR30019-R	300					15.3							
HR25026-R	250	100.0	50.0	57.2	22.1	119.6	55.4	64.2	63.5	9.5	313.8	32000	24.8
HR30026-R	300												22.5
HR45026-R	450												18.1
HR30048-R	300	125.0	56.0	66.7	25.3	143.7	67.6	76.1	76.2	12.7	475.6	48500	38.2
HR45048-R	450												30.5
HR60048-R	600												26.7
HR30054-R	300												52.2
HR45054-R	450	140.0	65.0	77.0	31.6	169.3	81.6	87.7	76.2	16.0	529.6	54000	41.2
HR60054-R	600												35.6