

HB-type Attachments

A-1, K-1 Attachment

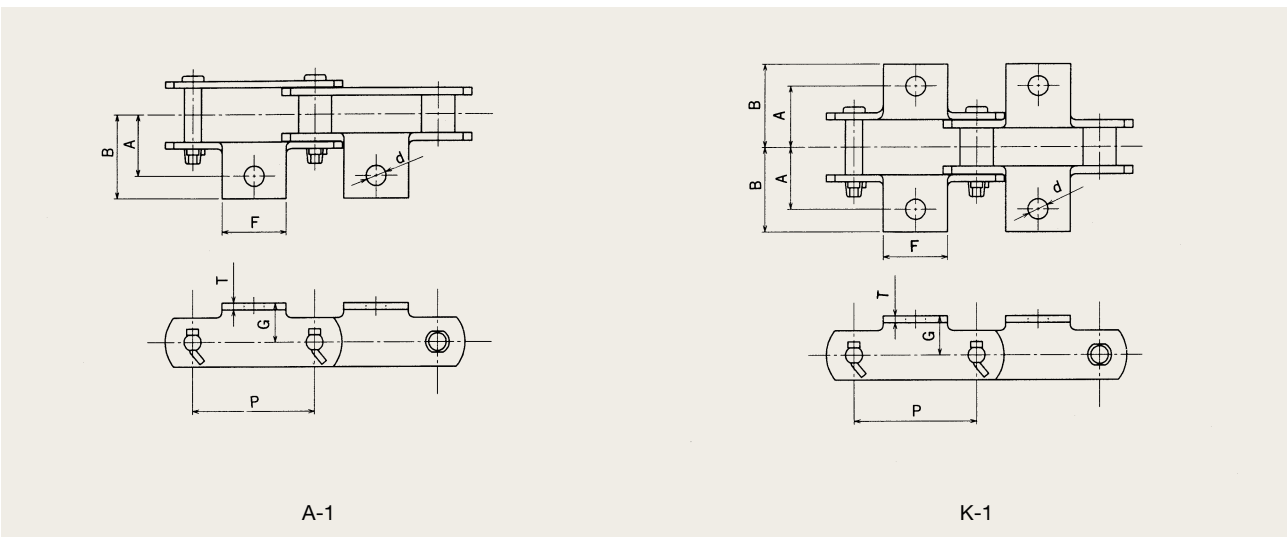

Chain No.	Pitch P (mm)	Dimensions (mm)						Added Mass per Attachment (kg)	
		A	B	d	F	G	T	A-1	K-1
HB6608	66.27	45	64	12	35	24	6.3	0.10	0.20
HB7811	78.11	60	78.5	12	45	35	7.9	0.15	0.30

A-2, K-2 Attachment

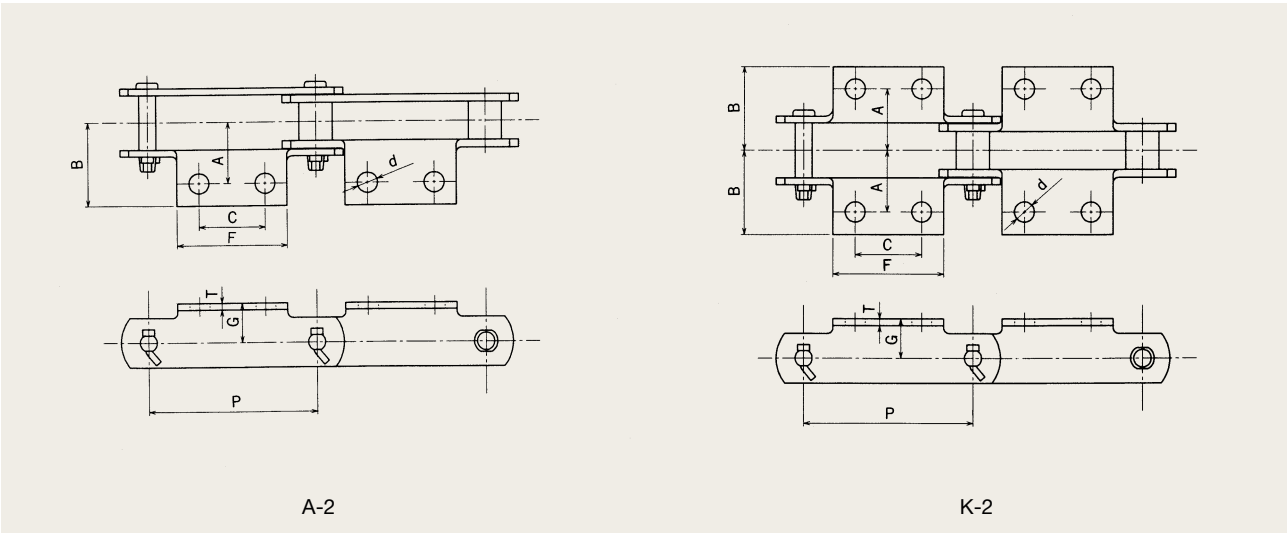

Chain No.	Pitch P (mm)	Dimensions (mm)							Added Mass per Attachment (kg)	
		A	B	C	d	F	G	T	A-2	K-2
HB7811	78.11	60	78.5	30	12.0	65	35	7.9	0.25	0.50
HB10007	100	35	52	40	10.0	65	22	4.8	0.10	0.20
HB10011	100	50	64	40	12.0	70	28	6.3	0.15	0.30
HB15011	150	50	64	60	12.0	90	28	6.3	0.20	0.40

Standard Conveyor Chains

G-2 Attachment

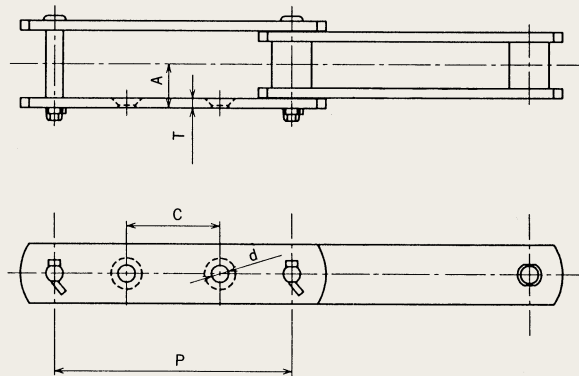

G-2

Chain No.	Pitch P (mm)	Dimensions (mm)			
		A	d	C	T
HB10007	100	20.5	10.0	40	4.8
HB10011	100	28.1	11.0	35	6.3
HB15011	150	28.1	11.0	60	6.3